



UniPay™



Mobile Audio Jack MSR and Smart Card Reader

Compact Magnetic Stripe and Smart Card Reader

ID TECH's UniPay is the latest addition to the audio jack family of mobile card readers. UniPay incorporates contact chip, smart card reading, with proven and reliable magnetic stripe decoding which results in a compact mobile reader. Its small form factor and audio jack interface is ideal for mobile applications where either magnetic stripe and/or smart card reading are required.

Mobile Form Factor and Audio Jack Interface

ID TECH's UniPay communicates to the host via the audio jack port and is supported on Apple and Android platforms with a SDK, to allow for simple and easy integration into mobile payment applications. Also featured, is a USB port which can be used for charging or communication with a PC. The UniPay's efficient design minimize power consumption to the host device battery life.

Payment Certifications

UniPay is EMV Level 1 and Level 2 approved through the SDK and uses DUKPT Key management and TDES/AES encryption to ensure magnetic stripe and smart card transactions are encrypted and transmitted securely to the host device. The UniPay is an approved solution of the Visa Ready Program and meets the Visa Ready requirements for a reliable, convenient, and secure hardware solution.

Features and Benefits:

- Approved solution of the Visa Ready Program
- Audio headphone jack communication for the latest Apple iOS and Android platforms
- EMV Level 1 and Level 2 approval
- RoHS 2 and REACH compliance
- TQM Label
- Low power consumption when reader is in standby mode
- Compact and ergonomic design to integrate with a variety of mobile devices
- Encrypted MSR and chip card reader with DUKPT key management
- Micro-USB port for pass-through charging and PC communication
- 1 year manufacturer warranty

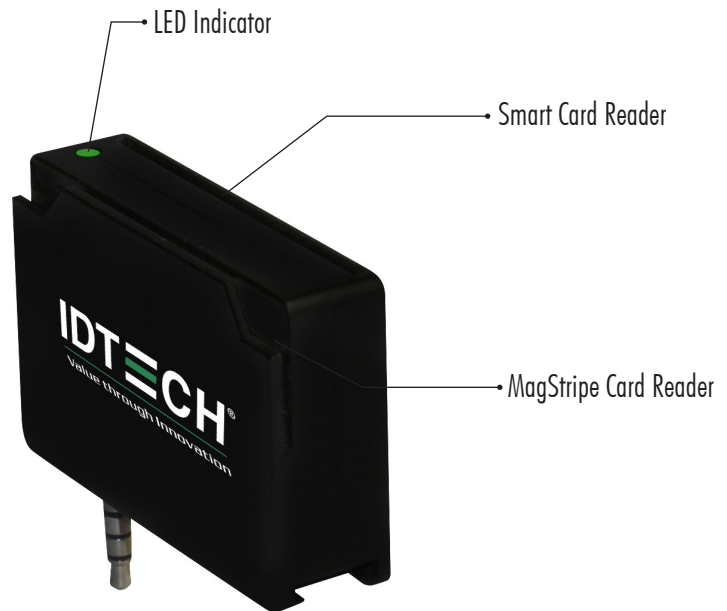

UniPay™

Specifications IDMR-AJ80133B

Electrical

Interfaces: Audio headphone jack

Environmental

Operating Temperature: 32°F to 131°F (0°C to 55°C)
Storage Temperature: -22°F to 158°F (-30°C to 70°C)
Humidity: Maximum 95% non-condensing

Reliability

Operating Life: MagStripe Reader: 300,000 card swipes minimum
Smart Card Reader: 100,000 card cycles minimum

Warranty: One year, parts and labor

Approvals: EMV Level 1 and EMV Level 2, ROHS, FCC/CE

Mechanical

Dimension (L)x(W)x(H): 2.36 inches (60 mm) x .63 inches (16 mm) x 2.25 inches (57.2 mm)

Media Thickness: 0.027 inches (0.6858mm) minimum
0.035 inches (0.8382mm) maximum

Card Seated Switch: ICC fully-seated sensor

Color: Black

Footprint:

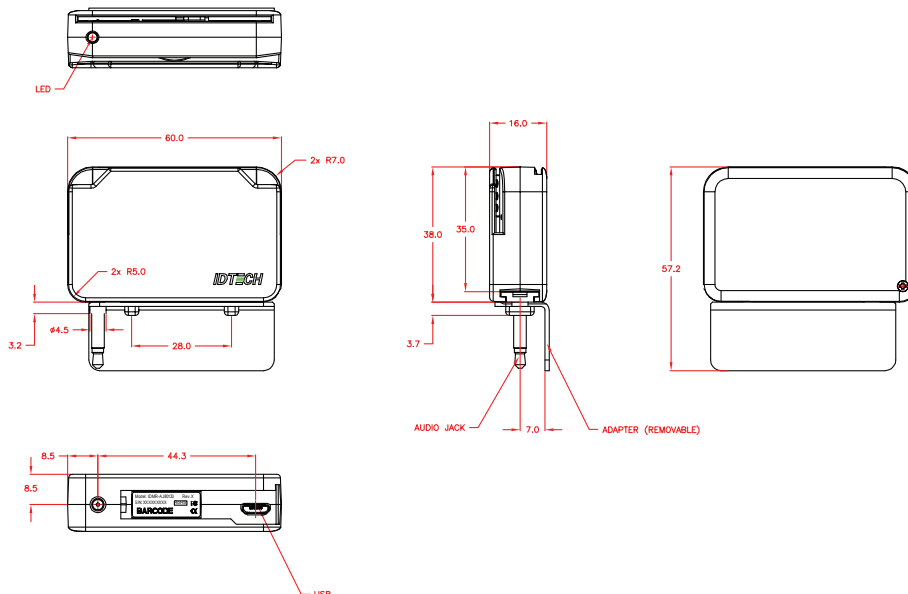

United States Sales Office

Corporate Headquarters

10721 Walker Street
Cypress, CA 90630
Phone: (714) 761-6368
Toll Free: (800) 984-1010
Fax: (714) 761-8880
sales@idtechproducts.com

International Sales Offices

Asia

+866-3-496-6988 (Taiwan)
asia@idtechproducts.com.tw

Canada

+450-465-5261
robertop@idtechproducts.com

South America

+55-11-3079-2255
internationalsales@idtechproducts.com

Europe

Germany & United Kingdom
emea@idtechproducts.com

ISO 9001 Certified



Value through Innovation

www.idtechproducts.com